

EXHIBITOR MANUAL

Springfield Sportsmen's Show

DIRECTORY

[Aisles and Passageways](#)

[Badge Order Form](#)

[Booth Dimensions and Bulk Area Information](#)

[Booth Furnishings Order Form](#)

[Contacts](#)

[Directions](#)

[Display Vehicles Requirements](#)

[Drayage](#)

[Electricity for Booth](#)

[Exhibitor Additional Ticket Form](#)

[Exhibitor Move In Information](#)

[Exhibitor Take Down Information](#)

[Firearms for Display Information](#)

[Fire Prevention Information](#)

[Fire Safety Regulations](#)

[First Aid & Medical Emergencies](#)

[Food Exhibitors](#)

[Health Regulations](#)

[Hotel](#)

[Internet Service](#)

[Miscellaneous Information](#)

[Noise Levels of Displays](#)

[Music & Copyrights](#)

[Parking for Exhibitors](#)

[Pets & Animals](#)

[Retail Sales Tax Information](#)

[RV Parking](#)

[Security](#)

[Show Hours](#)

[Telephone Request Form](#)

RETAIL SALES TAX INFORMATION

All exhibitors who are selling retail products must have a **Massachusetts Sales Tax Identification Number**. After you receive your ID please mail us a copy for our files. We **must** have this information **before** you set up your display. To reach the MA Department of Revenue, please contact:

New Contact: Gary Grenier 1-508-792-7300 ex 22208
email address grenier@dor.state.ma.us
internet www.mass.gov/dor

Directions: Click on [MassTax Connect](#) for instructions on how to register for Mass Sales Tax.



NEED HELP? If you need help, you can call the following numbers:
In-State: **800-392-6089** Out-of-State: **617-887-6367**

EXHIBITOR MOVE IN INFORMATION

ENTRANCE: Entrance onto the grounds of Eastern States Exposition will be at Storowton entrance.

EXHIBITOR CHECK-IN: The show office is in the Better Living Center at Door #7.

MOVE IN: Move-in begins on Thursday starting at 9am. On Friday, move in will begin at 8am and continue until the show opens at noon. Snow and ice must be cleaned off vehicle before entrance into the building. This is for everyone's safety, as well keeping snow from entering other exhibitor's booths.

EXHIBITOR TAKE DOWN INFORMATION

No display is to be dismantled or removed from the show floor until the show closes at 5pm on Sunday. At the end of the show exhibitors may hand carry their booth out of the building. At 5:30 the overhead doors will be opened for vehicles to enter the building. Take down will continue until 10pm. On Monday takedown will continue at 9AM until noon. At this time all vehicles must be out of the building.

No display is to be disassembled or removed off the show floor prior to the show closing on Sunday night. We recommend that all small and portable items be removed immediately after the show closes on Sunday. There is no security coverage after the show closes on Sunday.

SHOW HOURS

Friday	noon	to	8pm
Saturday	9am	to	7pm
Sunday	10am	to	5pm

Exhibitors will be allowed into the building 1 hour before the show opens each day. There will be a limited amount of doors open before the show. In the Better Living Building Door # 7 will be open. In the Young Building Door # 7. For any other doors open check with the door people.

ELECTRICITY

At the show one 110v, 20 amp electrical outlet will be provided for your booth at no additional cost. **You will need to bring extension cords and electrical adapters**, as outlets may not be directly behind your booth. Additional electrical needs must be requested in advance and will be charged according to the electricians' rates. Please turn off all electricity at your booth when you leave for the night.

EXHIBITOR PARKING

There is a \$5. a day parking fee. You may park in any designated space. Parking will not be permitted in fire lanes, against buildings, grassy areas or any other NO PARKING designated areas. Vehicles not parked in designated areas will be ticketed and/or towed.

FIRE SAFETY REGULATIONS

All electrical extension cords, lights, wiring and hook-ups must meet UL and National Code (1993 edition) requirements as well as state and local ordinances. All decorative materials, banners, cloth, skirting and carpeting must be flame retardant. The use of untreated materials is prohibited. Propane tanks are not permitted in buildings. Also flammable liquids are only allowed if approved by the Fire Marshall prior to the show. No open flame is allowed.

FIRST AID & MEDICAL EMERGENCIES

The First Aid station is located in the Better Living Center by Door #6. In the event of a medical emergency requiring immediate attention at the scene, contact a show employee or Security Guard for assistance.

**EXHIBITOR MANUAL
Springfield Sportsmen's Show**

**Manual
Directory**

BOOTH FURNISHINGS ORDER FORM

PACKAGE A: 10 X 10 booth
1 8' draped table 30"
2 folding chairs
1 9 x 10 rug **Cost: \$125**

PACKAGE B: 10 x 20 booth
2 8' draped tables 30"
4 folding chairs
1 9 x 20 rug **Cost: \$190**

PACKAGE C: 10 x 30 booth
3 8' draped tables 30"
5 folding chairs
1 9 x 30 rug **Cost: \$270**

PRICING FOR ADDITIONAL ITEMS

4', 6', or 8' 30" high bare table @ \$40 each
4', 6', or 8' 40" high bare table @ \$50 each
4', 6', or 8' 30" high skirted table @ \$60 each
4', 6', or 8' 40" high skirted table @ \$80 each
Seating: Upholstered bar stool \$55, Upholstered side chair \$45, Folding chair \$5
Rugs: 9 x10 Rug \$90, 9 x 20 Rug \$180, 9 x 30 Rug \$235
Stanchion with cord at \$25.00 per set

NOTE: Exhibitors may bring their own furnishings for their booth(s).

I would like the following items: _____

@ the cost of: _____ CREDIT CARD #: _____

SECURITY CODE #: _____ Expiration Date: _____

Company Name: _____

Contact Person: _____

Telephone #: _____

All orders must be accompanied with either a credit card or check made payable to:
OSEG
PO Box 207
Granby, MA 01033

**EXHIBITOR MANUAL
Springfield Sportsmen's Show**

**Manual
Directory**

EXHIBITOR BADGE FORM

COMPANY NAME _____
(company name at it appears on contract)

Please print the names of all workers who will be working your booth during the Show. **Each Exhibitor will receive 4 badges.** Exhibitors with more than one booth will receive two more badges for each additional booth. If you need more badges they may be purchased below at a discounted fee. Badges are for booth workers only. They are not guest passes.

SPORTSMEN'S SHOW - SPRINGFIELD, MA.

If additional badges are needed please order them on the additional ticket form below:

EXHIBITOR ADDITIONAL TICKET FORM

ORDER FORM FOR ADDITIONAL BADGES AND CUSTOMER TICKETS

Each additional badge or ticket is being offered to you at a cost of \$12 and will be good for any day of the show.

Please send your check to OSEG with your order.

I would like _____ (tickets or badges) at the cost of \$12.00 each.

Mailing address for tickets

SECURITY

There will be security during all days of the show with security ending Sunday at 5pm. However exhibitors are responsible for their own products. If you notice any unauthorized personal in any booth please contact the show office.

BOOTH DISPLAY AND BULK AREA

This information is for a basic 10 x10' booth: 8' high draped back wall. The back wall isn't strong enough to hang anything on it. 32" high draped sidewalls. Your booth can not block another booths side view. Exhibitor sign (if ordered by Decorator's deadline)

Decorator's Phone: 508-757-3397

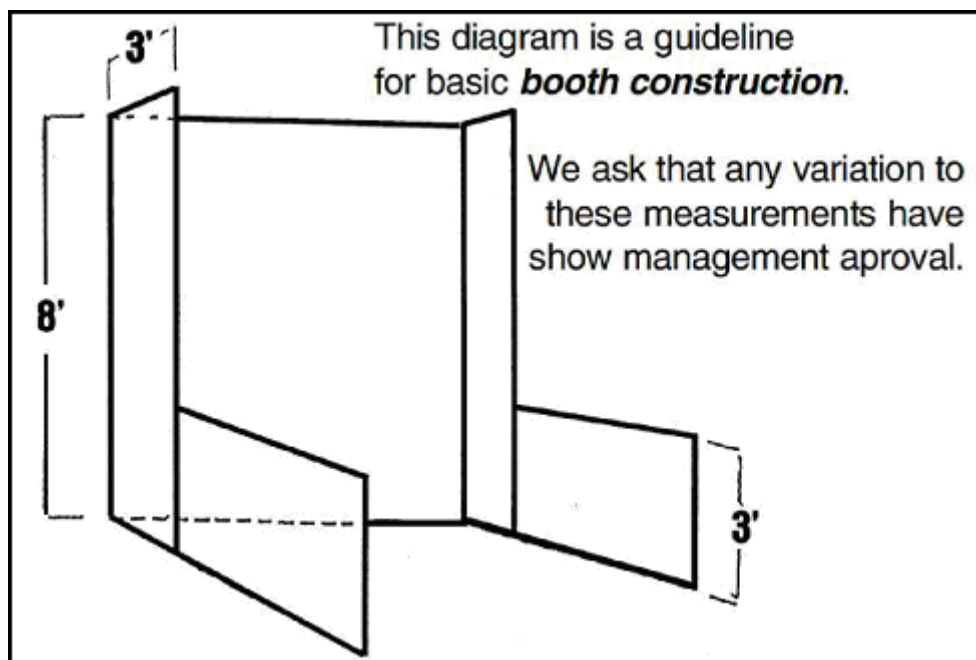

*** Bulk area is floor space only. You will have to provide your own pipe and drape.

*** **The front and sides of your booth can not block the view of other vendors**

BURLAP MATERIAL IS NOT ALLOWED AS BACK DROP OR TABLE COVERING. ALL FABRICS USED AS BACK DROPS AND/OR TABLE COVERINGS MUST BE FLAME RETARDANT, USE OF SPRAY FLAME RETARDANTS IS ACCEPTABLE.

MUSIC, COPYRIGHTED

Music will not be permitted by exhibitors unless it is in compliance with all copyright and/or other laws applicable to the playing of such music. Exhibitors are solely liable for any music played regardless of whether such music is contained on a video/audio tape, compact disc or electronically transmitted by radio or television or by any other means.

DISPLAY VEHICLES IN BUILDING DURING SHOW

All gasoline tanks must be sealed with a locking gasoline cap or taped shut. All gas tanks must contain less than 1/8 of a tank of fuel. Battery connections must be disconnected from the battery and taped. This is per order of the Fire Marshal.

PETS & ANIMALS

Pets and animals (with the exception of guide dogs) are not permitted in the buildings. The only animal allowed in the show buildings are if they are part of an exhibit or participating in a demonstration. All pets and animals that are part of the show must be restrained at all times. Owners of pets and animals are solely and completely responsible and liable for the behavior of their animals. Owners are also responsible for any cleanups or damage done to buildings and booths. **OSEG has the right to refuse any and all animals into the buildings.**

FIREARMS FOR DISPLAY

All exhibitors displaying or selling firearms and ammunitions must have the required federal permits with them. All federal and state and local regulations must be complied with. Handguns must be secured at all times.

MISCELLANEOUS

- All aisles shall be clear of displays and equipment.
- No exhibitor is allowed to place literature, banners or signs outside of the booth area.
- No nails, tacks, tape, stickers or other material will be allowed on any part of the building.
- Signs and banners are not allowed on the sprinkler systems.
- All exits and emergency equipment must remain accessible at all times.
- Smoking is not permitted in any of the buildings.

FOOD EXHIBITORS

All exhibitors who have been approved to sell or sample food must be in compliance with all local and state codes. All health permits and regulations must be adhered to.

All food vendor must get a food permit from the Board of Health, West Springfield, MA in order to participate at the show. A copy of this permit must be forwarded to our office.

Please read this letter from the [West Springfield Health Department](#)

You must contact the Board of Health a minimum of 45 Days before the show.

Their phone number and the application can be found here:

<http://www.townofwestspringfield.org/Home/ShowDocument?id=1378>

In order to set up your booth at the show OSEG needs to have a copy of your health permit on file at our office at least **2 weeks before** the show. We have to have enough time to send a copy to Eastern States Exposition. They will not allow you to set up at the show without a copy of your permit.

RV SELF-CONTAINED VEHICLES

There is a parking area with electrical hook-ups only. There is no septic or water hook-ups available. Please call Eastern States Exposition for costs and general information. Tel. 413-737-2443

INTERNET SERVICE

Wireless Internet Service is provided by SkyTech. For wireless connection go online and SkyTech will open and you can follow the directions for obtaining service.

NOISE LEVELS

Exhibitors are requested to observe common courtesy regarding the level of noise which any exhibit or display may make. The use of sound devises, sideshow tactics or similar methods of attracting attention is prohibited without consent from Show Management. Show management reserves the right to decide what will be allowed.

AISLES

The aisles and passageways are to remain free and clear. Exhibitors and their personnel must remain within the confines of their own spaces. No exhibitor will be permitted to erect signs or display products outside of their space. Show management reserves the right to remove any and all violations.

CONTACT INFO

SHOW MANAGEMENT

Outdoor Sports Expo Group Inc
P.O. Box 207
Granby, MA 01033
Tel. (413) 467-2171
Fax. (413) 467-2174
E-mail: dougoseg@gogtt.net
or reneoseg@gogtt.net
WEB: www.osegshows.com

SHOW OFFICE

(413) 205-5061
In the Better Living Center Door # 7

DRAYAGE

Special Events Rentals
1060 Millbury St.
Worcester, MA 01607
Tel. 1-800-527-2175

SHOW LOCATION

Eastern States Exposition 1305
Memorial Ave.
West Springfield, MA 01089
Tel. (413) 737-2443
www.thebige.com

All shipment to the show will be handled by Special Event Rentals. For information and rates please call 1-800-527-2175.

DIRECTIONS TO THE SHOW

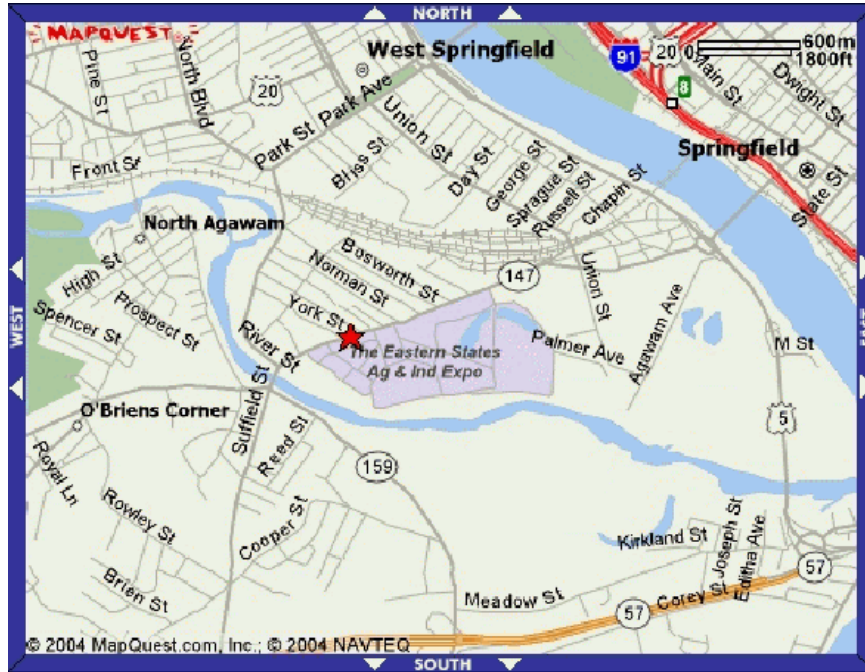

I-91 Traveling South

Take exit 7 off the highway and take a right at the light and go over the bridge and pick up route 147 west at the rotary (Memorial Avenue) and travel approximately 2 miles and the Eastern States Exposition will be on your left.

I-91 Traveling North

Take I-91 North from Rte. 2, I-84, I-95 or the Merritt Parkway -- Follow I-91 North to Mass. Exit 6 (Springfield Center). Follow East Columbus Avenue to Boland Way (Springfield Sheraton). Go left at the light, continue over the Memorial Bridge and follow Rte. 147 West, Memorial Avenue approximately 3/4 mi. to Eastern States Exposition's Gate 9 parking lot.

I-90, MA Turnpike, East or West

Take exit 4 and pick up route 5 south after the tollbooth. Travel route 5 south to route 147 west at the rotary. Travel approximately 2 miles and the Eastern States Exposition will be on your left.